



# WASTE HANDLING SOLUTIONS LTD

## The Saphir Automatic Range



**350T**

The SAPHIR range are built to meet the ever demanding requirements of clients to enable the recycling of various materials.



**500AT**

**800AT**



**600AT**

- Fully Automatic tying systems
- Capacities from 1.5 tonnes to 20 tonnes per hour
- Shear blades fitted as standard
- Ancillary feed systems, to include pneumatic, conveyor, hand, bin-lift
- Large loading apertures for speed of loading
- High bale densities up to 1000KG
- Uniform bale sizes for maximum payload
- Design, installation and training by UK staff.



**WASTE  
HANDLING  
SOLUTIONS LTD**

***"Making Sense Out Of Rubbish"***

**[www.waste-handling-solutions.com](http://www.waste-handling-solutions.com)**

**Tel : 01454 228899**

As the sole UK suppliers of the Saphir range from **SACRIA**, WHS Ltd can supply a whole range of fully automatic tying horizontal baling presses to suit each clients specific applications.

## **SACRIA** SAPHIR HORIZONTAL BALER – DIMENSION SPECIFICATIONS

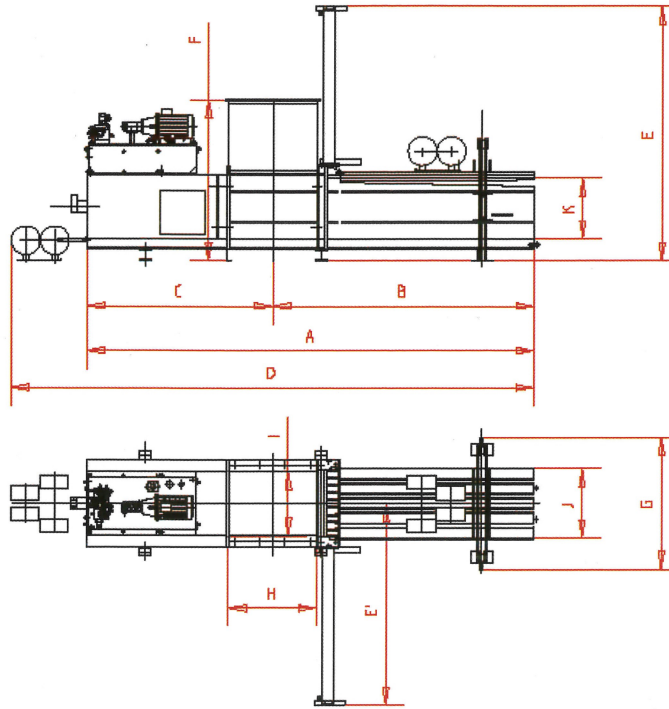

Models highlighted are available with vertical or horizontal tying systems; please see E & E'

MODEL NO	FORCE	A	B	C	D	E	E'	G	H	I	J	K
SAPHIR 15	15T	4570	2160	2410	4930	2430	-	1100	1080	640	700	500
SAPHIR 25	25T	5800	2975	2825	5800	2850	2300	1300	1180	640	700	700
SAPHIR 40	40T	5800	2975	2825	5800	2850	2300	1300	1180	640	700	700
SAPHIR 300	30T	6000	3510	2490	7050	3450	3000	1780	1200	900	900	810
SAPHIR 340	40T	6000	3510	2490	7050	3450	3000	1780	1200	900	900	810
SAPHIR 350	50T	6000	3510	2490	7050	3450	3000	1780	1200	900	900	810
SAPHIR 450	45T	5570	3450	2600	6620	3450	-	1780	1400	1000	1000	800
SAPHIR 500	50T	7000	4510	2490	8050	3450	-	1780	1200	900	900	810
SAPHIR 600	60T	6640	3620	3020	7690	3450	3000	1850	1400	1000	1000	810
SAPHIR 800	80T	7480	4235	3245	8530	3450	3000	1780	1200	1000	1000	810

### **"MAKING SENSE OUT OF RUBBISH"**

- 12 Month on site warranty with UK engineers
- Consumables available from stock
- Design facilities to include MRF installations
- Rental & Lease options available